



RAVAS-1100

A PALLET TRUCK SCALE FROM THE LEADER IN MOBILE WEIGHING

RAISES EFFICIENCY AND SIMPLIFIES LOGISTIC PROCESSES, SAVES TIME AND SPACE

FOR CHECKING INCOMING GOODS, DETERMINING SHIPPING WEIGHTS, AVOIDING OVERLOADS

4 STANDARD AA BATTERIES, WHEN USED 5 TIMES A DAY, THE BATTERIES LAST FOR A YEAR.

LOW POWER CONSUMPTION; AUTOMATIC SWITCH-OFF

FUNCTIONS

- ◆ Automatic and manual zero correction
- ◆ Gross/net weighing
- ◆ Totaling with sequence number
- ◆ Error messages in display
- ◆ Automatic switch-off after 3 minutes of non-use
- ◆ Low battery indication in display



Indicator functions : tare, gross/net weighing, totaling with sequence number

RAVAS

DIMENSIONS

A	Fork length	:	1150 mm
B	Fork width	:	180 mm
C	Minimum fork height	:	85 mm
D	Maximum fork height	:	200 mm
E	Width over forks	:	555 mm
F	Height to top indicator	:	565 mm

PRECISION STANDARD VERSION

Graduation : Graduation 1 kg

STANDARD SPECIFICATIONS

Weighing capacity	:	2000 kg
Display	:	LCD, digit height 18 mm
Keypad	:	3 function keys, on / off key
Protection class	:	load cells and cabling IP67, indicator IP65
Steering wheels	:	rubber
Loading wheels	:	polyurethane, tandem
Colour	:	red (RAL 3000), epoxy painted
Own weight	:	122 kg
Battery	:	4 x 1.5V AA-batteries
Battery life	:	When used 5 times a day, the batteries last for a year

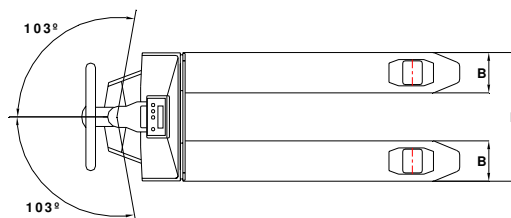
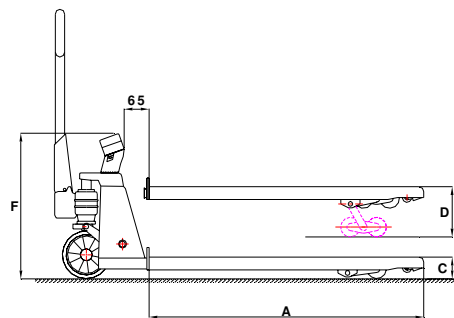

OPTIONS HAND PALLET TRUCK *

Stainless steel version

* For special options the specifications can differ from standard specifications

RAVAS

RAVAS Europe B.V.

P.O. Box 2023

NL-5300 CA Zaltbommel

The Netherlands

+31 – (0) 418 - 51 52 20

* +31 – (0) 418 - 51 53 20

info@ravas.com

www.ravas.com

Rev.27.06.07