

The Domino DDC3

The third generation digital laser coder that sets new levels of reliability and versatility, and offers an even wider range of capability.

A Reputation for Reliability

With a heritage of unmatched reliability, the new DDC3 was developed to eliminate unplanned downtime. It incorporates Domino's exclusive sealed CO₂ laser tubes, designed and manufactured in-house and proven on the world's production lines. This air-cooled coding system operates without moving parts or consumables, ensuring virtually maintenance free coding. It features new, state-of-the-art power-supply technology for cooler operation and ultimate system reliability. While the IP56/NEMA4 control cabinet provides protection against the most extreme working environments, the remote laser head is shock resistant and features new self-aligning optics that eliminate time intensive adjustments.



Extended Flexibility by Design

Domino's exclusive new **Rainbow™** laser tubes allow high quality coding on a wider range of substrates. Within each

selectable range, laser power can be custom tuned, using the integrated control panel, to the precise level needed for your coding application. From the hardest industrial ceramics to the thinnest PET or thermoplastics, your products can be reliably and consistently coded without perforating the material. The digitally generated characters are permanent and completely indelible.

The DDC3 is fully programmable, delivering higher efficiency at far lower, safer power levels.

The small footprint of the control cabinet and the exclusive choices of two long, flexible umbilicals, 14 feet (4.3m) or 38 feet (11.5m), allow the slim printhead to be fitted and positioned anywhere on the production line. Single head, or Domino's exclusive dual head models are capable of printing up to two lines per head without loss of coding speed, and can code without distortion onto curved surfaces like the neck of a bottle.

Easy to Use

Designed with today's busy operator in mind, the colour VGA display and WYSIWYG software simplify operation. It is easy to set up or change codes using the full sized keyboard. Special "HOT" keys are also available for the most frequently used functions.

Costs Less to Operate and Maintain

The sealed CO₂ laser tubes eliminate the need for consumables and water cooling systems and are designed for years of trouble free operation. Direct high efficiency optics enable superior coding at far lower power levels without the need for moving parts or computer-controlled beam delivery schemes. The DDC3 is easily the coolest running, highest efficiency, most reliable laser coder ever built.

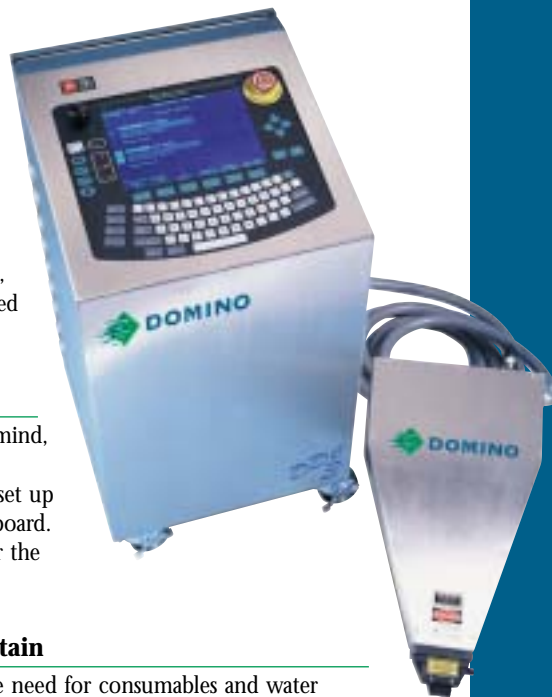

Paper Label – Salad Dressing



Chipboard Carton – Cereal Box



Polycarbonate – Video Cassette



Coated Carton – Frozen Food



PETE/PET – Water Beverage Bottle

Exclusive DDC3 Advantages

- **Rainbow™** Range of Laser Tubes
- High Efficiency, 7 Channel Direct Digital Coding
- Dual Laser Head Capability
- Longest Most Flexible Umbilical
- No Moving Parts or Consumables
- UL and TÜV Listings



The Domino DDC3

Technical Specifications

Laser type:	Sealed CO ₂ RF excited, gas consumption nil
Data entry and display:	Video user interface with integrated control panel and color VGA screen
Lines of text:	Up to two lines per head
Character generation: (substrate dependent)	Up to 2000/sec (single line) or 4000/sec (twin line); up to 3300/sec (single line) or 6600/sec (twin line) with Black LEEP laser tubes
Line speed (substrate dependent):	820ft/min (250m/min) 1310ft/min (400m/min) – Black LEEP lasers
Print formats:	5x5, 7x5, 7x9, PC font, Arabic font
Character height range:	0.04" up to 0.40" (1.0mm up to 10mm)
Standard Software features:	Sequential numbering, batch numbering, full clock options, password protection, user defined symbols, WYSIWYG message entry
Message length:	Up to 253 characters per message
Inputs:	Shaft encoder, product detector, external interlocks, fume extraction status monitoring, plus two user-configurable inputs
Interface:	RS232 std., RS422 or RS485 optional
Outputs:	<ul style="list-style-type: none"> ◆ Three colour status beacon kit ◆ 3 voltage free relays suitable for interface to line stop ◆ Voltage free relays for controlling fume extraction and compressed air laserhead cooling ◆ Two user-configurable outputs
Flexible conduits:	14' (4.3m) and 38' (11.5m)
Power requirements:	100-240 VAC, 6A, 50-60Hz (single head) 100-240 VAC, 12A, 50-60Hz (dual head)
Air cooled laser head:	Plant air required typically 3.5 SCFM (100 litre/min) at 10psi minimum (duty cycle and ambient temperature dependent)
Control cabinet cooling:	Ambient air-cooling with optional fan pack may be required for high duty cycle and high ambient temperature
Environmental standard:	IP56, NEMA 4
Operating temperature:	41-113°F (5-45°C)
Humidity:	10-100% non-condensing (operating)
Cabinet:	Stainless steel
Dimensions:	30.5" high X 17.1" wide X 18.6" deep (775mm high x 435mm wide x 472mm deep)
Weight:	Approx. 146lbs (66kg)
Regulatory Standards:	UL, cUL, TÜV, CDRH, CE mark

Dimensions

Cabinet

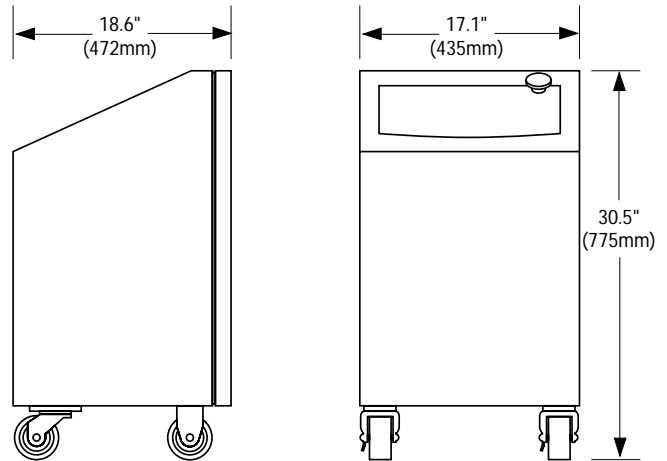

Laser print head

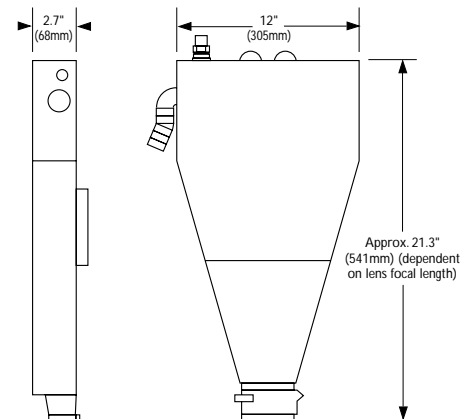

Domino Amjet Inc.
1290 Lakeside Drive,
Gurnee, Illinois 60031 USA
Tel: +1-800-323-4754
Fax: +1-847-244-2645
www.domino-printing.com

Domino UK Ltd
Bar Hill
Cambridge CB3 8TU UK
Tel: +44 (0)1954 782551
Fax: +44 (0)1954 782874
www.domino-printing.com

